

	V	I	R	P
R1			8	
R2			16	
R3			24	
R4			30	
R5			20	
R6			6	
T	150			

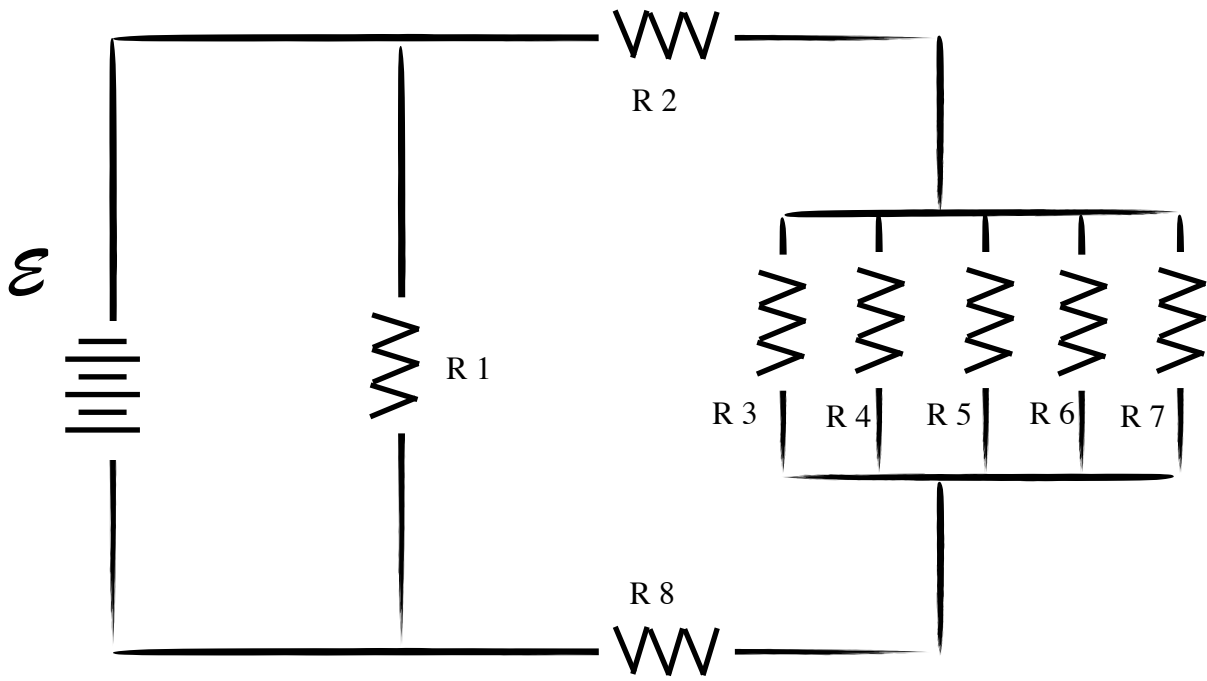

	V	I	R	P
R1		5		
R2	75			
R3			50	
R4		1		
R5	50			
R6		1		
R7			50	
R8		5		
T	150			

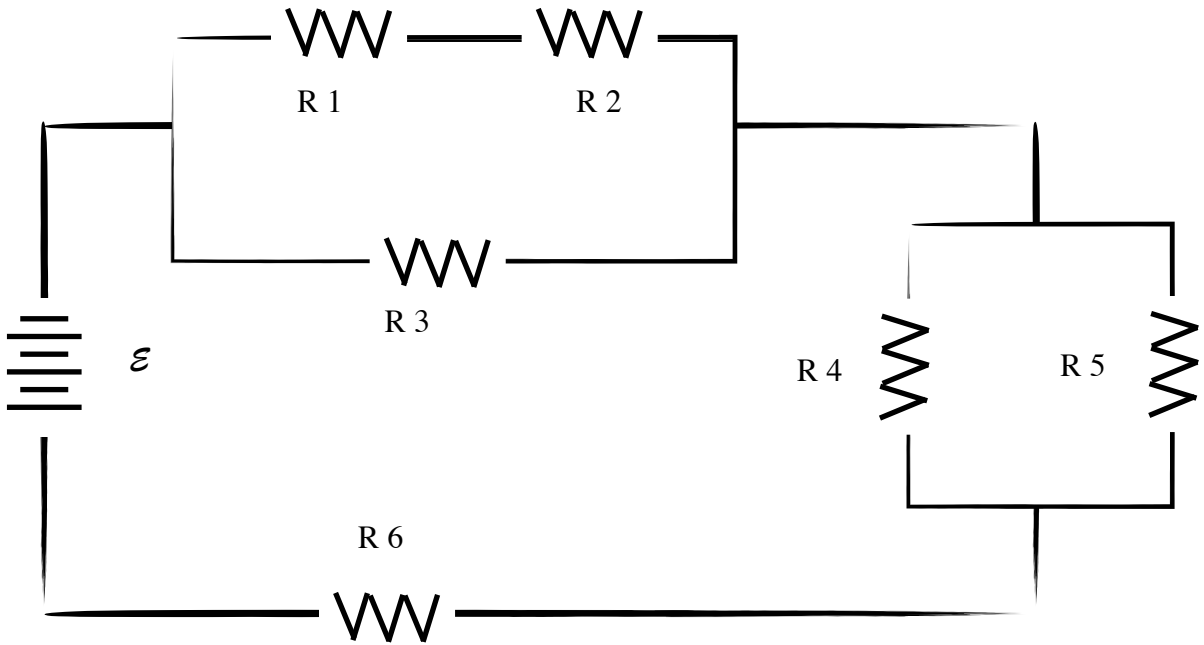

	V	I	R
R1	3.5		
R2			5
R3		1.5	
R4	4.0		
R5		1.0	
R6			2
T		2.0	

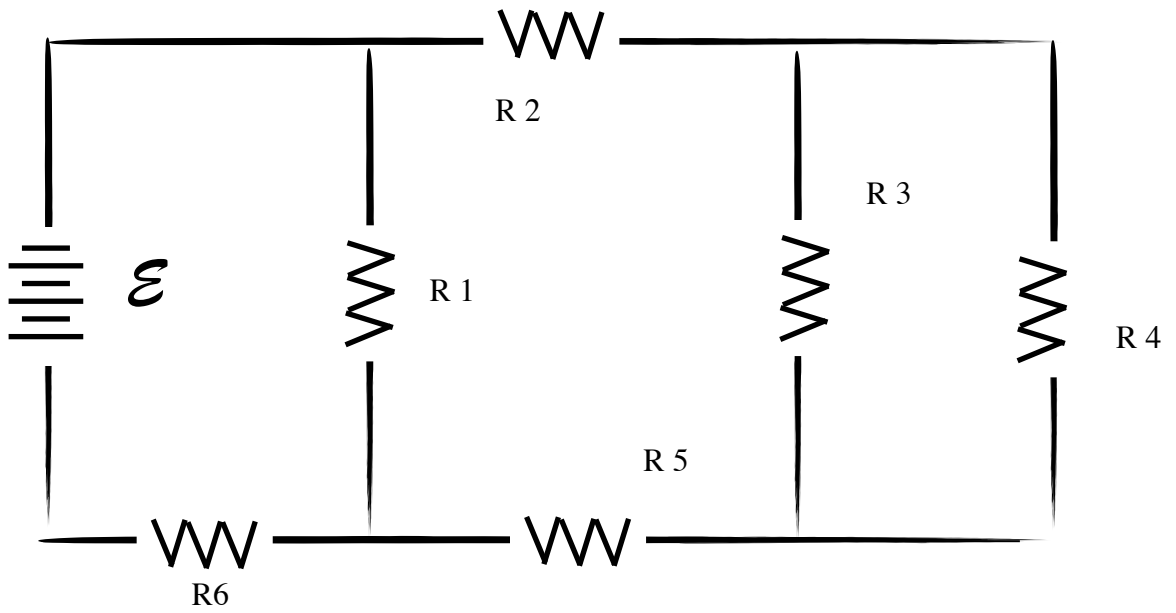

	V	I	R	P
R1		8		
R2		2		
R3	10			
R4			10	
R5			9	
R6			0.375	
T	43.75			

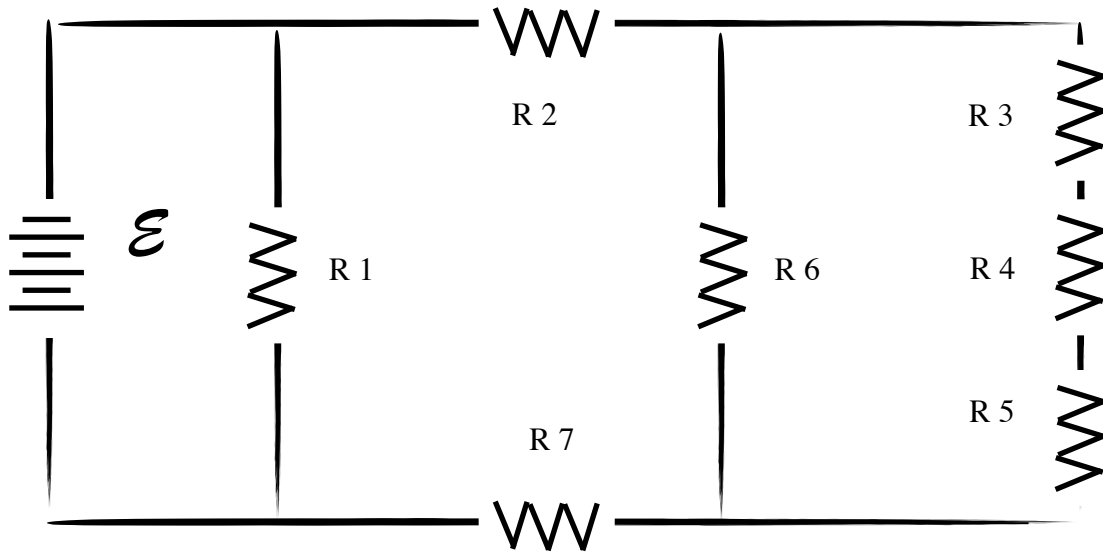

	V	I	R	P
R1			90	
R2			24	
R3			3	
R4			4	
R5			5	
R6			12	
R7			30	
T	180			

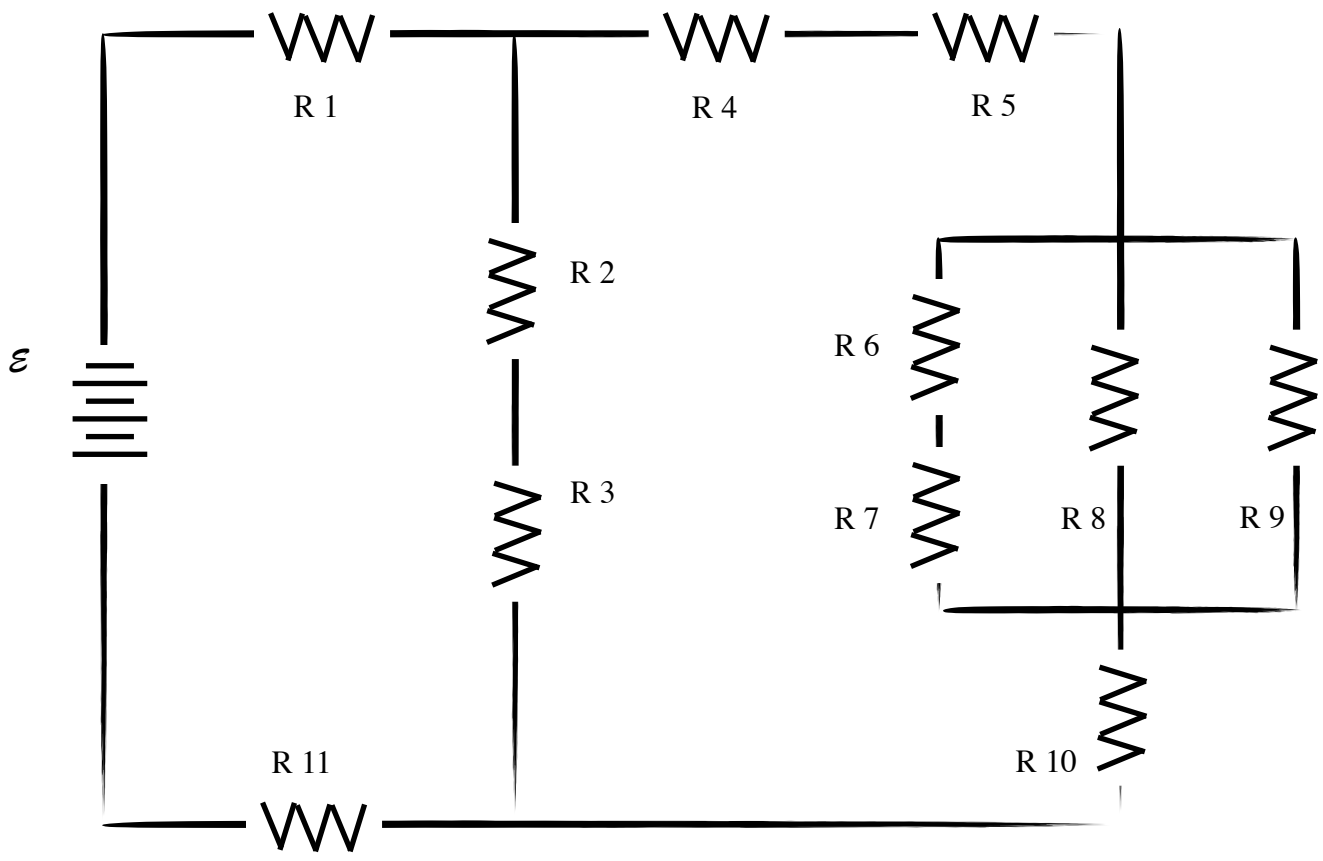

	V	I	R	P	E (60s)
R1			25		
R2			15		
R3			45		
R4			5		
R5			7		
R6			10		
R7			20		
R8			30		
R9			30		
R10			8		
R11			15		
T	180				

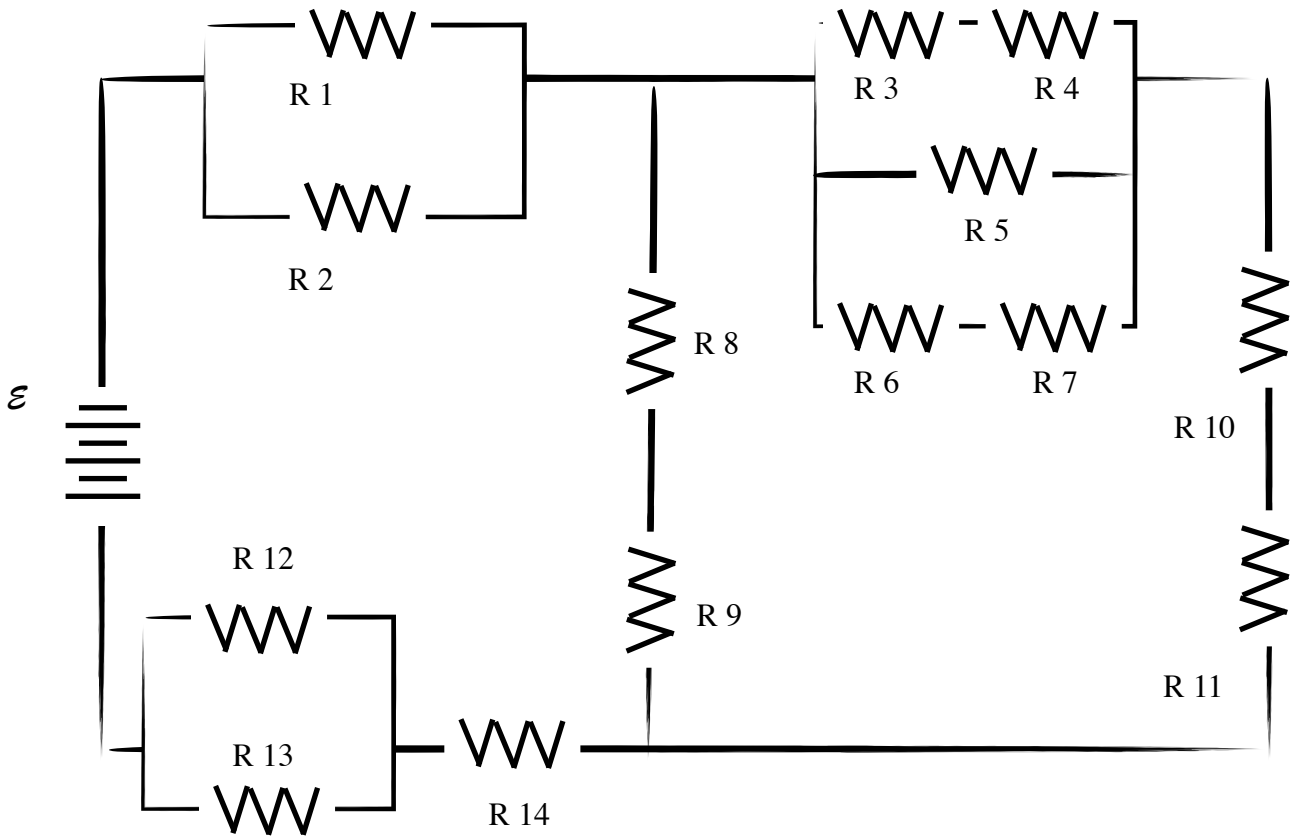

	V	I	R	P
R1			10	
R2			10	
R3			5	
R4			10	
R5			15	
R6			8	
R7			7	
R8			20	
R9			40	
R10			10	
R11			15	
R12			12	
R13			60	
R14			5	
T	240			