

| lecture problem | V | I | R | P |
|-----------------|-----|---|----|---|
| R1 | | | 8 | |
| R2 | | | 16 | |
| R3 | | | 24 | |
| R4 | | | 30 | |
| R5 | | | 20 | |
| R6 | | | 6 | |
| T | 150 | | | |

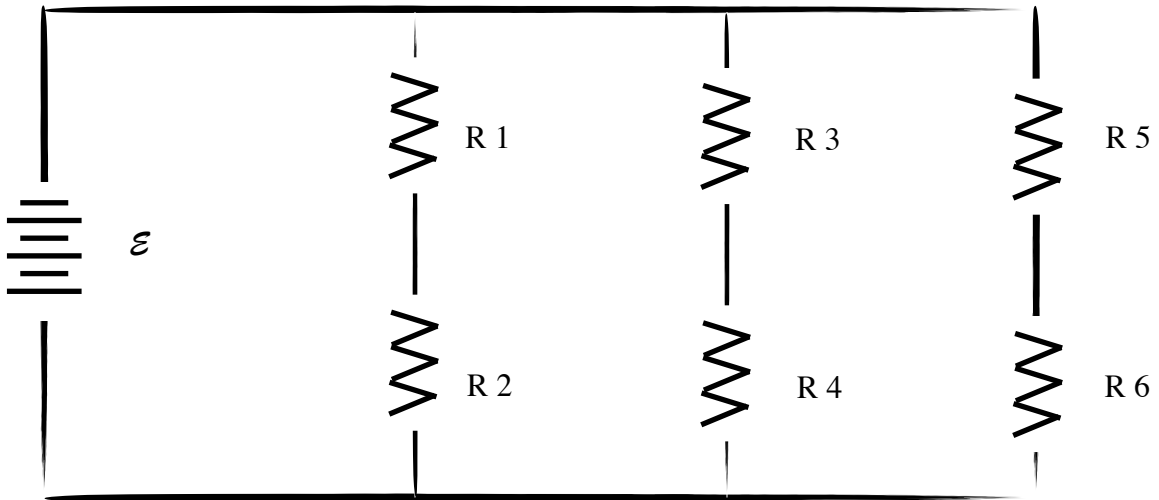

| | V | I | R | P |
|----|------------|---|----|---|
| R1 | | | 10 | |
| R2 | | | 8 | |
| R3 | | | 12 | |
| R4 | | | 18 | |
| R5 | | | 6 | |
| R6 | | | 3 | |
| T | 180 | | | |

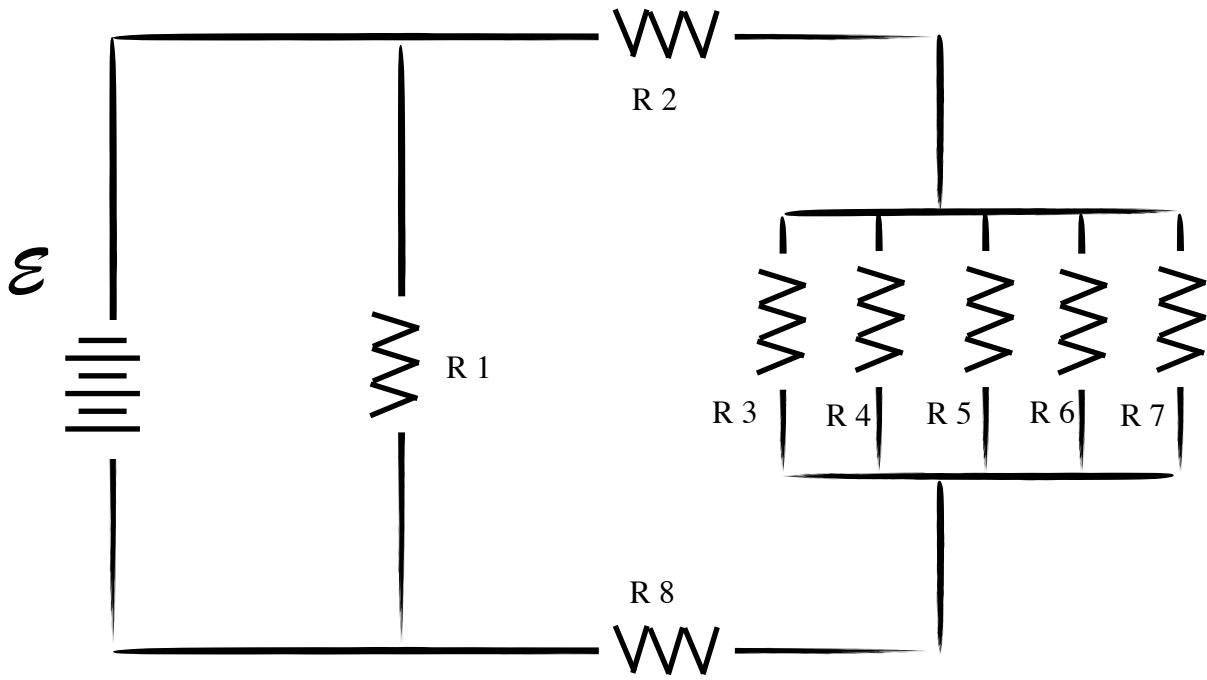

| | V | I | R | P |
|----|-----|---|-----|---|
| R1 | | | 24 | |
| R2 | | | 8 | |
| R3 | | | 60 | |
| R4 | | | 120 | |
| R5 | | | 120 | |
| R6 | | | 20 | |
| R7 | | | 60 | |
| R8 | | | 6 | |
| T | 240 | | | |

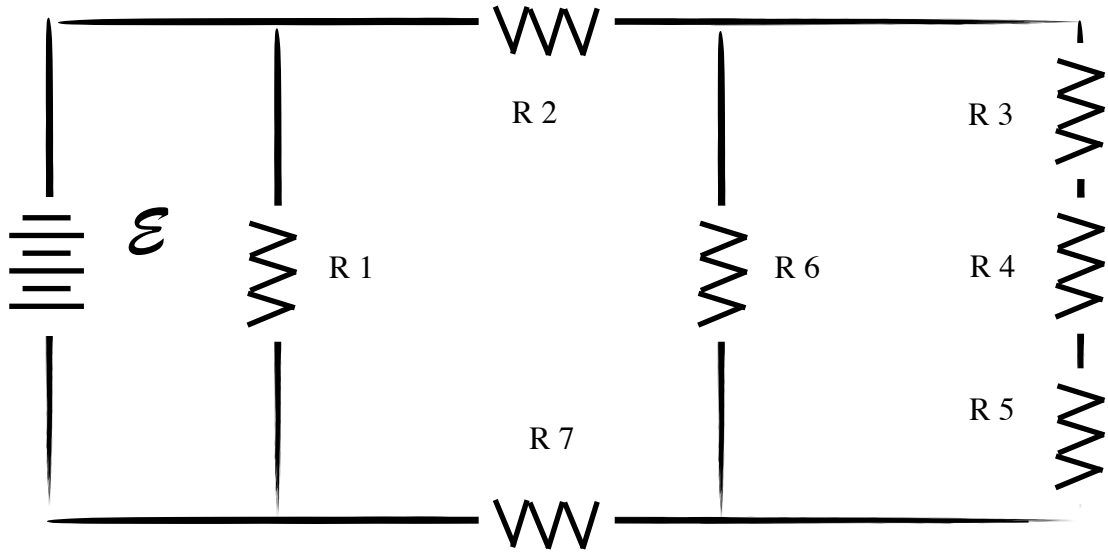

| | V | I | R | P |
|----|-----|---|----|---|
| R1 | | | 90 | |
| R2 | | | 24 | |
| R3 | | | 3 | |
| R4 | | | 4 | |
| R5 | | | 5 | |
| R6 | | | 12 | |
| R7 | | | 30 | |
| T | 180 | | | |

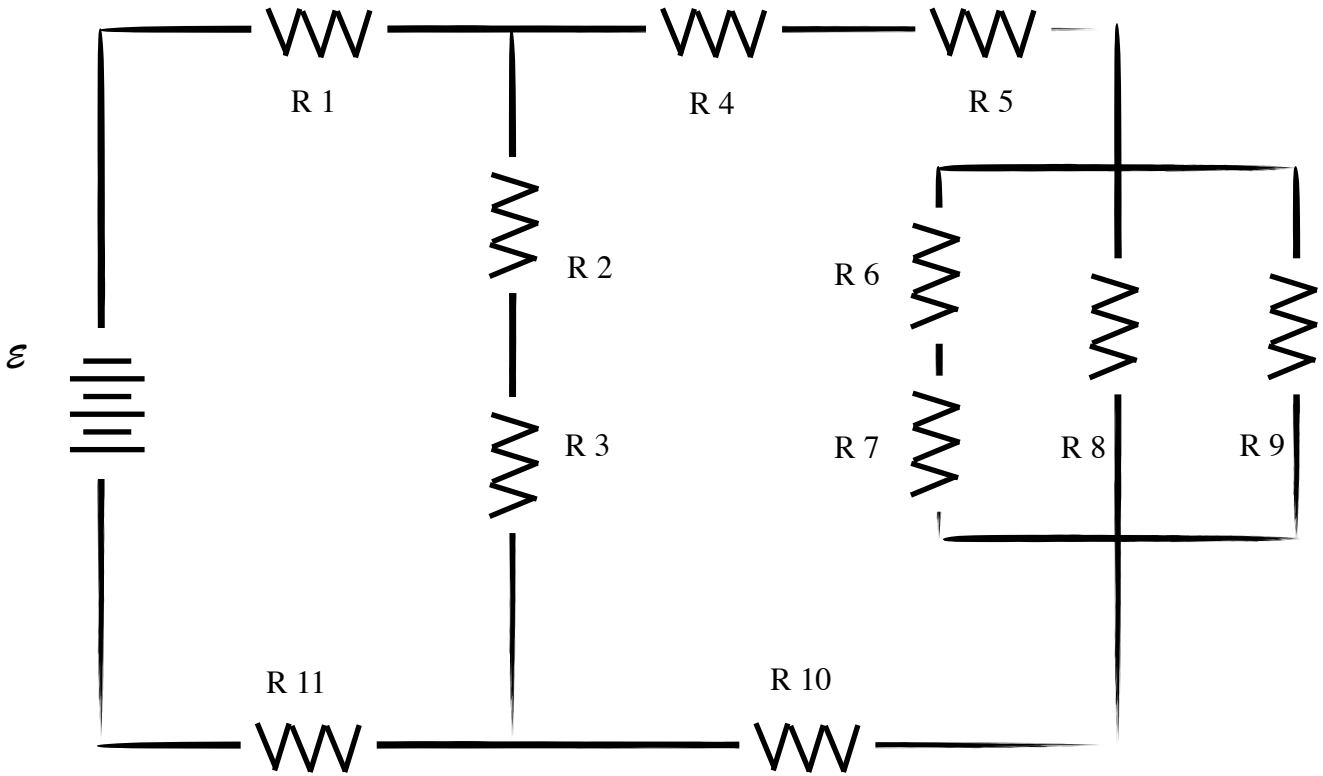

| | V | I | R | P | E (60s) |
|-----|----|---|----|---|---------|
| R1 | | | 25 | | |
| R2 | | | 15 | | |
| R3 | | | 45 | | |
| R4 | | | 5 | | |
| R5 | | | 7 | | |
| R6 | | | 10 | | |
| R7 | | | 20 | | |
| R8 | | | 30 | | |
| R9 | | | 30 | | |
| R10 | | | 8 | | |
| R11 | | | 15 | | |
| T | 54 | | | | |

problems 19b

1. 2. It is claimed that a certain camcorder battery can provide a potential difference of 9.60 V and a current of 1.50 A. What is the resistance through which the battery must be discharged?
2. 3. A prototype electric car is powered by a 312 V battery pack. What is the resistance of the motor circuit when $2.8 \times 10^5 \text{ C}$ passes through the circuit in 1.00 h?
3. 4. In 1992, engineers built a 2.5 mm long electric motor that can be driven by a very low emf. What is the potential difference if it draws a 3.8 A current through a 0.64Ω resistor?
4. 5. A team from Texas A&M University has built an electric sports car with a maximum motor current of 2400 A. Determine the potential difference that provides this current if the circuit resistance is 0.30Ω .

problems 19c

5. 1. A generator at a central electric power plant produces electricity with a potential difference of $2.5 \times 10^4 \text{ V}$ across power lines which carry a current of 20.0 A. How much power does the generator produce?
6. 2. An electric sports car was developed several years ago at Texas A&M University. If the potential difference across the car's motor is 720 V and the resistance was 0.30Ω , how much power was needed for the car to run?
7. 3. A light bulb has a filament with a resistance of 144Ω , while a second bulb has a filament with a resistance of 240Ω . Both bulbs are connected across a 120 V outlet. Which light bulb is brighter?

[Hint: The brightest bulb uses the most power.]

8. 4. A microwave oven requires 1750 W of power to cook food. If the oven is plugged into a 120 V outlet, what is the resistance in the oven's circuit?
9. 7. A blender requires 350 W to power the rotating blades that chop food. If the blender has a resistance of 75Ω , how much current passes through the blender's circuit?

problems 20 A

10. 1. A $16\ \Omega$ resistor is connected in series with another resistor across a 12V battery. The current in the circuit is 0.42 A. Calculate the value of the unknown resistance.
11. 2. A $24\text{-}\Omega$ resistor is connected in series with another resistor across a 3.0-V battery. The current in the circuit is 62 mA. Calculate the value of the unknown resistance.
12. 4. A string of holiday lights has 73 light bulbs in series. Each light bulb has a resistance of $3.0\ \Omega$. Calculate the equivalent resistance.
13. 6. In case of an emergency, a corridor on an airplane has 57 lights wired in series. Each light bulb has a resistance of $2.0\ \Omega$. Find the equivalent resistance.

Problems 20b

14. 1. A $3.3\ \Omega$ resistor is connected in parallel with another resistor across a 3.0 V battery. The current in the circuit is 1.41 A. Calculate the value of the unknown resistance.
15. 3. An $18\ \Omega$ resistor is connected in parallel with another resistor across a 1.5 V battery. The current in the circuit is 103 mA. Calculate the value of the unknown resistance.
16. 4. A $39\ \Omega$ resistor, an $82\ \Omega$ resistor, a $12\ \Omega$ resistor and a $22\ \Omega$ resistor are connected in parallel across a potential difference of 3.0 V. Calculate the equivalent resistance.
17. 7. A refrigerator and an oven are wired in parallel across a potential difference of 120V. The refrigerator has a resistance of $75\ \Omega$ and the oven has a resistance of $91\ \Omega$. How much current is in the circuit of each appliance?
18. 8. A computer and a printer are wired in parallel across a potential difference of 120 V. The computer has a resistance of $82\ \Omega$ and the printer has a resistance of $24\ \Omega$. How much current is in the circuit of each machine?

4. Determine the equivalent resistance of the complex circuit shown at right.

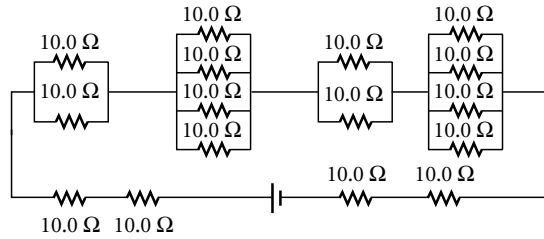

5. Determine the equivalent resistance of the complex circuit shown at right.

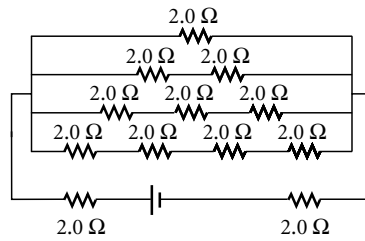

6. Determine the equivalent resistance of the complex circuit shown at right.

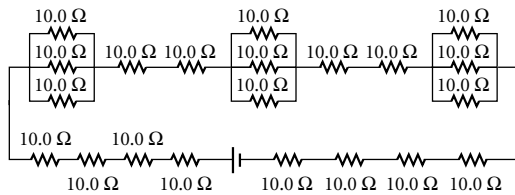

7. What will be the net current for the circuit shown at right?

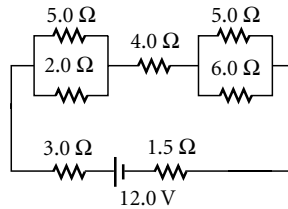

8. What will be the net current for the circuit shown at right?

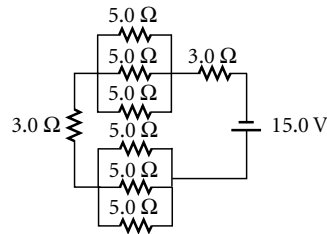

9. What will be the net current for the circuit shown at right?

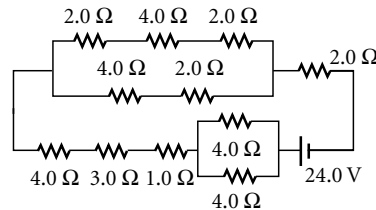

10. What will be the net current for the circuit shown at right?

